

DINGHY TOWING

RIG YOUR CAR TRUCK OR SUV TO SAFELY TOW BEHIND YOUR COACH

FRIDAY, JANUARY 4, 2008

BILLY THIBODEAUX'S PREMIERE RV, INC



There's more to Towing than Tow Bars

Dinghy towing is a serious topic and no one has more experience in rigging your dinghy with The Right Stuff!

Tow Bars, Brackets, Lighting, Braking & Tire Pressure Monitoring

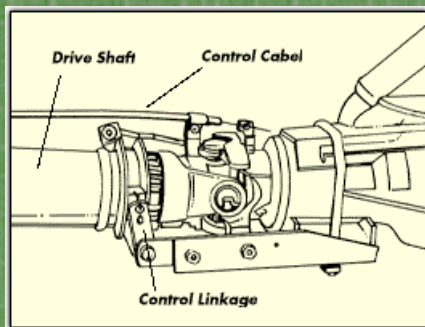

- Take the guess work out of dinghy towing!
- Let the professionals at Billy Thibodeaux's completely rig your dinghy for safe, worry-free towing
- Our systems bring you from go to tow in a couple of minutes
- Complete system demonstration when you pick up your rig
- Remco disconnects & lube pumps when needed expand the list of available tow vehicles
- Quality tow bars and mounts from only the leading manufacturers of towing equipment, Blue Ox and Roadmaster make connecting & disconnecting quick & easy.
- Braking systems from M&G & SMI get your rig stopped safely in 30% less distance, keeping you out of an accident.
- Tire Pressure Monitoring from Pressure Pro Systems keep you informed of coach & dinghy tire pressures

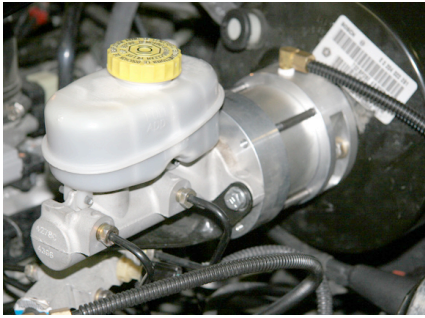

“The Right Stuff”

CALL BILLY BEFORE PURCHASING YOUR NEXT TOW CAR FOR A COMPLIMENTARY CONSULTATION!

Tow Bars & Brackets:

- GO FROM STOW TO TOW IN SECONDS !
- Blue Ox Aventa LX 10,000 lb. Ball & Socket tow bar
- Blue Ox Aladdin Aluminum 5,000 lb. capacity tow bar
- Roadmaster STERLING - “THE WORLDS STRONGEST” Aluminum tow bar
- Roadmaster Blackhawk 2 - 10,000 lb. capacity tow bar

Lighting:

- All tow vehicle rigs need appropriate lighting.
- We use bulb & socket kits whenever possible to avoid potential problems from interfacing with factory wiring
- Wiring diodes, properly installed, when installation of a bulb & socket kit installation is not possible.

Braking:

- Stop your rig in in 30% less distance.
- Safely control both the dinghy and motorhome with a properly fitted auxiliary tow brake system from SMI or M&G
- Avoid liability claims and unnecessary litigation because your rig is not properly equipped

Tire Pressure Monitoring

- Low tire pressure is the root cause of 80% of tire failures.
- A coach mounted monitor keeps tabs of tire pressures of the dinghy as well as the coach
- Wheel stem mounted sensor/transmitters communicate wirelessly with the coach monitor

Remco Lube Pumps & Drive Line Disconnects:

- Remco Drive Line Disconnects allow rear wheel drive vehicles that otherwise could not be towed four wheels down to enjoy the convenience of four down towing
- Remco Lube Pumps circulate transmission oil in select vehicles allowing those vehicles to be towed four-wheels down while keeping the tranny’s internals well lubricated. A special coach mounted audio/visual alarm notifies you if the umbilical cord disconnects or a problem occurs



Now in our new location! Take I-10 Exit 100, go South to Willow St, turn rt and follow to Mill St turn rt, for 9/10 mile Renaud Dr then rt to 1721 Renaud Dr, Scott, LA 70583

New Address
BILLY THIBODEAUX'S
PREMIERE RV, INC.
1721 RENAUD DRIVE, SCOTT, LA 70583

Office: 337-233-7424

Toll Free: 800-298-6953

Email: info@billyt.com